

# Politecnico di Torino – Italy

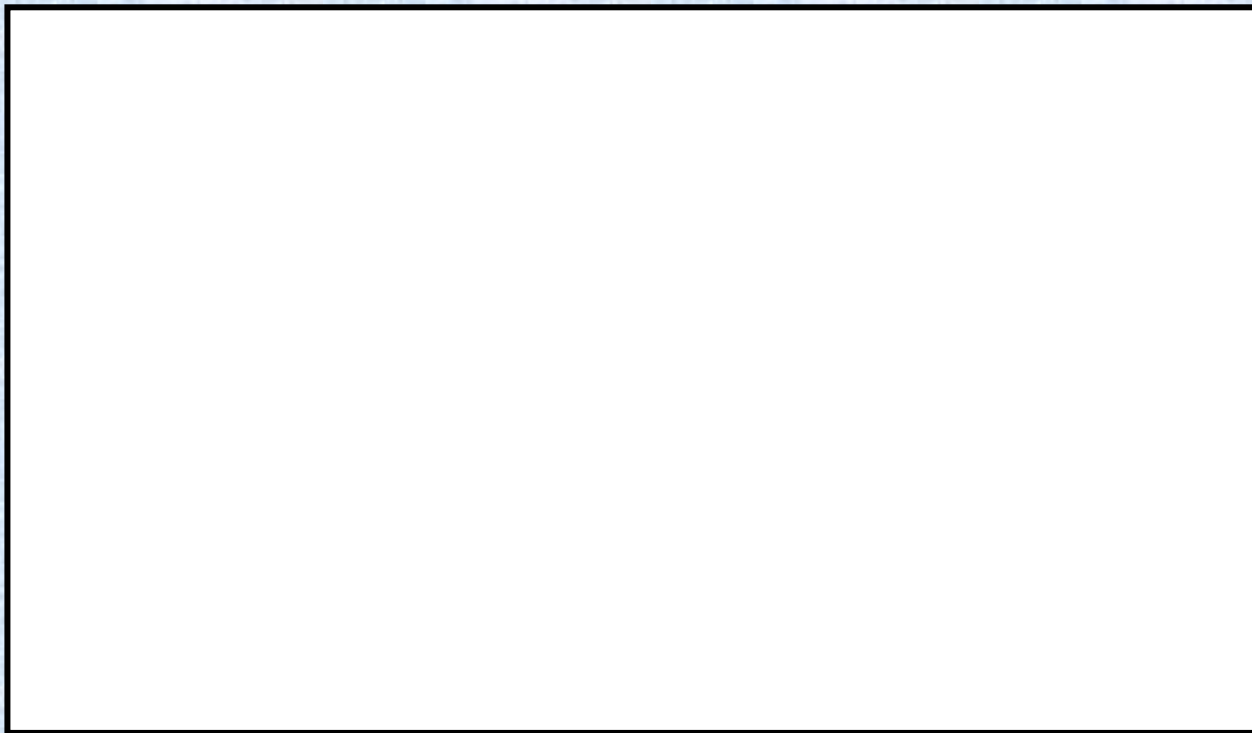

**Massimo Zucchetti**

# INTRODUCTION

- ✓ Nuclear fusion is seen as a much “cleaner” energy source than fission.
- ✓ However, the attractive safety and environmental potential of fusion can be fully realised by a design in which attention is paid to reducing the impact of materials activation and tritium inventory.

## **The Use of Fusion Fuels Will Evolve in the Future**

---

---

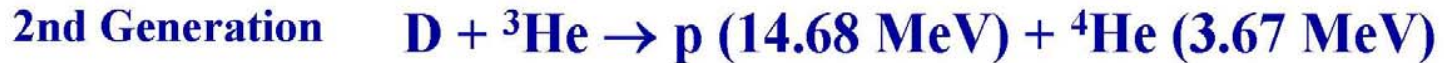

# Fusion Cross Sections for the First Three Generations

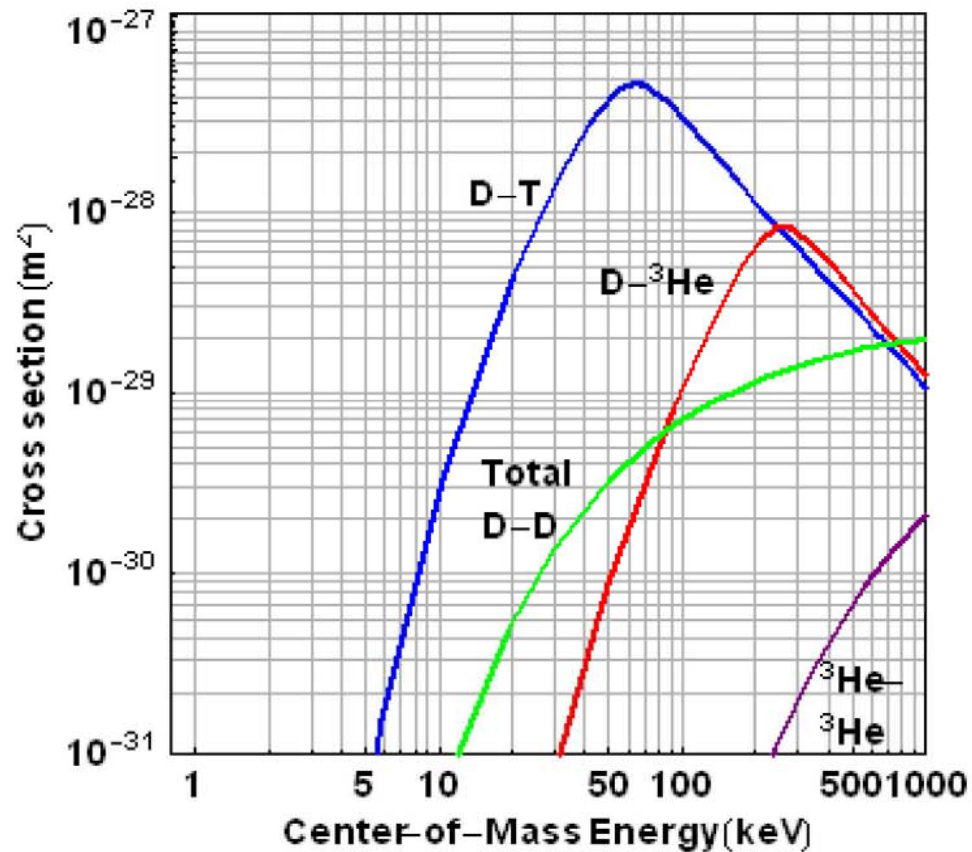

Source: J. F. Santarius

# Main disadvantages/problems of D-He3

1. The availability of  $^3\text{He}$  (almost absent on Earth, must be mined on the Moon, see following slides)
2. The attainment of the higher plasma parameters, required for burning, than D-T.

# Where is the Helium-3?



**There is 10 Times More Energy in the  
Helium-3 on the Moon Than in All  
the Economically Recoverable Coal, Oil  
and Natural Gas on the Earth**

# Significance of Lunar Helium-3

- 1 tonne of He-3 can produce 10,000 MWe-y of electrical energy.

- 
- A photograph of the Space Shuttle Columbia on the tarmac. The orbiter is white with black nose and wingtips. It has "NASA" and "United States" written on its side, along with a small American flag. The orbiter is attached to a white external tank and two white solid rocket boosters. The orbiter is on the ground, with its main landing gear and nose gear visible. The background is a clear blue sky and a sandy tarmac.
- 40 tonnes of He-3 will provide for the *entire* U.S. electricity consumption in 2004.

# Advantages of D-He3

- ✓ No need to breed and fuel tritium. No need for a breeding blanket. No radioactive fuel.
- ✓ Possibility to obtain electrical power by direct energy conversion of protons, avoiding to produce electrical power indirectly, via the usual heating of a thermo vector fluid (such as water or liquid metal) and its use in a thermodynamic cycle with a turbine

# Advantages of D-He3

- ✓ Very low presence of neutrons. In fact, the DHe3 cycle is not completely aneutronic, due to DD and DT side reactions: however neutron fluxes are quite much lower than for DT reactions
- ✓ Would the radioactive waste issue be completely solved with DHe3 fusion reactors?
- ✓ The “zero-waste” option is possible if all reactor components may be declassified to non-radioactive materials after a reasonable interim decay period.
- ✓ IAEA has issued in 2004 new “Clearance “ regulations

# The Number of Neutrons Generated by Helium-3 Fusion Fuels is Very Small

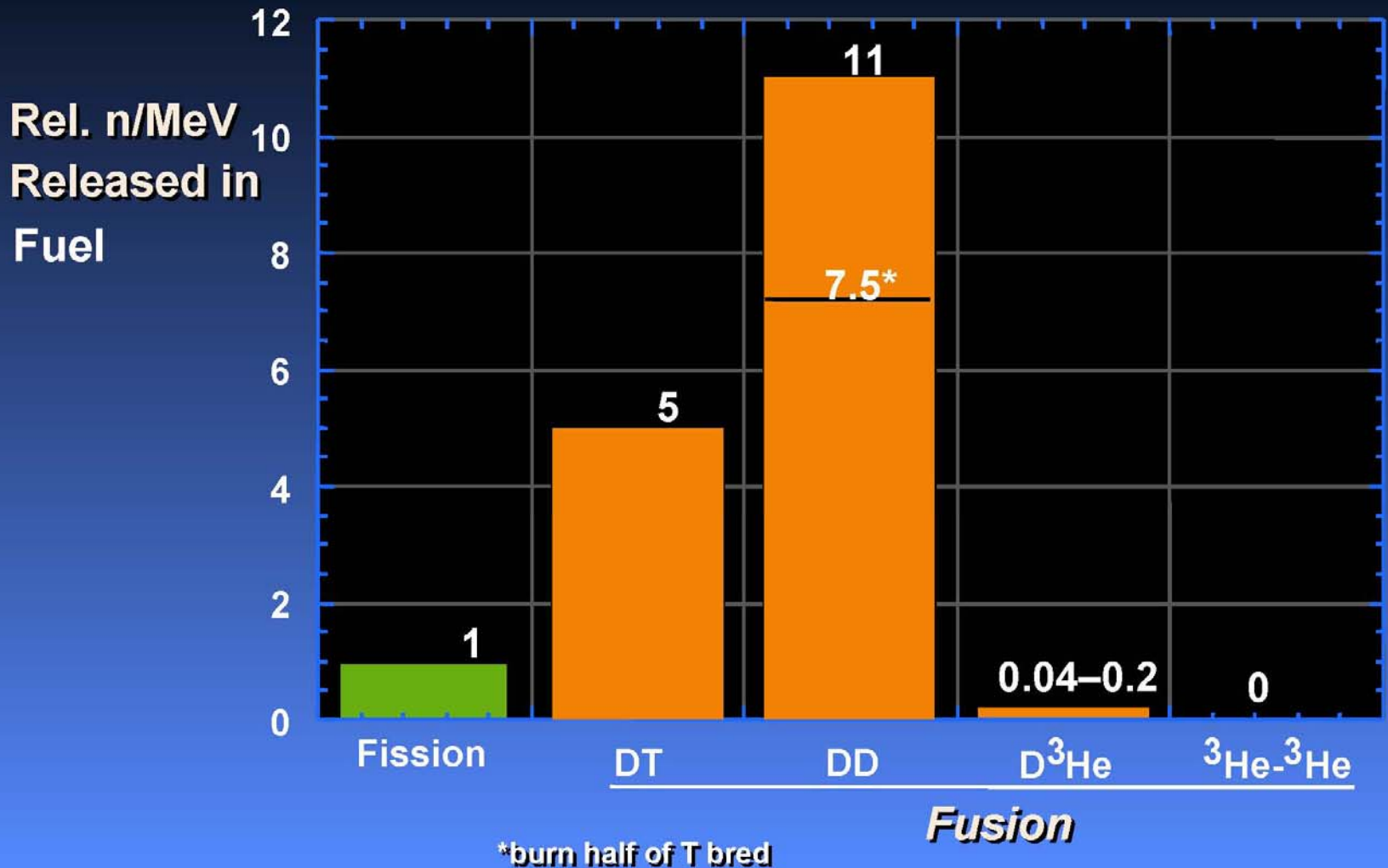

# A D-He3 Pathway

- ✓ Tritium-poor plasmas can reach ignition in drastically different conditions compared to fifty-fifty DT
- ✓ It is of particular interest to explore the physics of plasmas in which DHe3 or possibly the DD catalysed reactions play an important role.

# A D-He3 Pathway

- ✓ To begin to explore the possibilities of DHe3 plasmas, a DT burning plasma experiment at high field and plasma densities, which can be much closer to the required parameters than present-day experiments, is particularly attractive.
- ✓ Compact ignition tokamaks can be designed in order to achieve DHe3 ignition without excessive auxiliary heating, if a DT plasma is used as a ‘trigger’ for the DHe3 reaction.

# Compact Ignition Tokamaks

- ✓ Compact high-field experiments were the first to be proposed in order to achieve fusion ignition conditions on the basis of existing technology and the known properties of high-density plasmas.
- ✓ Good confinement and high purity plasmas have been obtained by high field machines Alcator/Alcator C/Alcator C-MOD at the Massachusetts Institute of Technology and Frascati Torus Upgrade (FT/FTU) at ENEA in Italy

# Ignitor: a first D-He3 step

- ✓ Ignitor is a proposed compact high magnetic field tokamak, and it is aimed at reaching ignition in DT plasmas and at studying them for periods of a few seconds.
- ✓ However, the plasma density limit in Ignitor is well above the optimal density for DT ignition, and it is suitable to the higher densities required for DHe3 burning.
- ✓ In fact, Ignitor has been also designed to satisfy conditions where protons and alpha particles produced by the DHe3 reactions can supply thermal energy to a well-confined plasma

# Ignitor: a first D-He3 step

- ✓ Ignitor can sustain plasma current exceeding that required to confine proton orbits at birth, and has high densities so that the slowing-down time of both protons and alpha particles is shorter than the electron energy replacement time of the thermal plasma in which they are produced.
- ✓ Preliminary analyses show that a fusion power  $P_F \cong 2 \text{ MW}$  may be reached.
- ✓ In particular, as a start, Ignitor can allow initial studies at the level of approximately 1 MW of power in charged particles from the DHe reaction in a mostly DT plasma

# IGNITOR

**Magnets:**  
Copper, Insulators

**Vessel (Vacuum Chamber):**  
INCONEL 625 Alloy

**Structural Material (C-Clamp):**  
AISI 316LN Steel

**First wall**  
Molybdenum

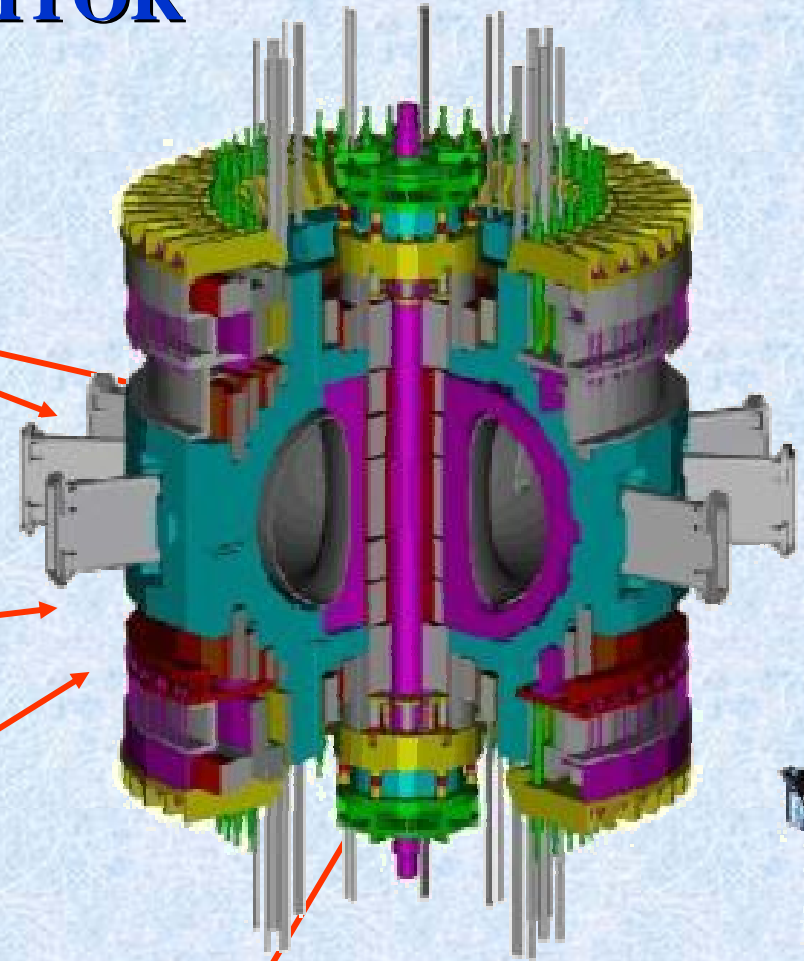

# Candor – Towards a DHe3 reactor

- ☞ The Candor experiment is a design evolution of Ignitor in the direction of a power reactor using a DHe fuel cycle.
- ☞ It has larger dimensions and higher fusion power than Ignitor, however is based on the same technologies
- ☞ The main characteristics of Candor are:
  - ☞ major radius  $R_o = 2.5$  m (about double than Ignitor)
  - ☞ plasma currents up to 25 MA
  - ☞ toroidal magnetic fields  $B_T \cong 13$  T

# Candor

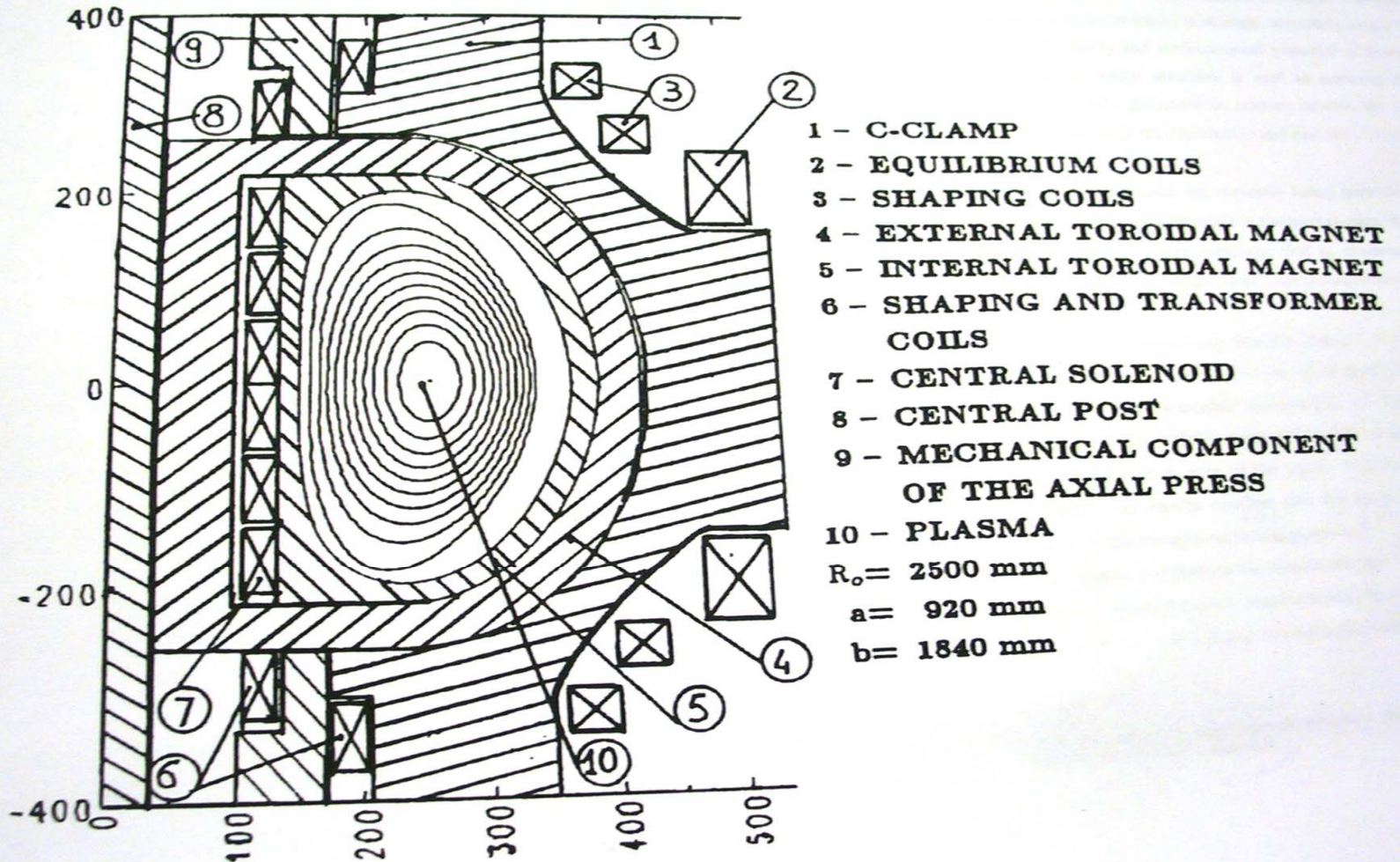

# Candor – Towards a DHe3 reactor

- ✎ Unlike Ignitor, Candor would operate with values of poloidal beta around unity and the central part of the plasma column in the Second Stability region.
- ✎ The DHe ignition regime can be reached by a combination of ICRF heating and alpha particle heating due to DT fusion reactions that take the role of a trigger.

# Candor – Towards a DHe3 reactor

- Thanks to DT trigger, and unlike other proposed DHe3 fusion experiments, Candor can reach DHe3 ignition on the basis of existing technologies and knowledge of plasma.
- The need for an intense auxiliary heating, which is one of the main technological drawbacks of DHe ignition, would be considerably alleviated.
- However, this method has the disadvantage of using some tritium and of presenting a higher neutron flux (due to DT trigger reactions) than ‘pure’ DHe3 plasmas.

# Candor: Any Radioactive Waste?

- ✎ The quantity and quality of radioactive waste from the machine operation and decommissioning has been estimated.
- ✎ No Candor spent material will need to be disposed of as permanent waste in underground repositories. All materials may be recycled, if convenient, after a short interim decay.
- ✎ Concerning clearance, all components but internal magnets may be declassified after less than 10 years of decay. For internal magnets, 20 years of interim decay are necessary

# Waste management study - Results

Component	Material	Time to become NAW
Internal Toroidal Magnets	Cu	Less than 20 years
Transformer Coils	Cu	Less than 10 years
External Toroidal Magnets	Cu	Less than 1 year
Structure (C-Clamp)	AISI 316	Less than 1 year
<b>TOTAL WASTE</b>		<b>ZERO, after 20 y</b> (100% Non Active Waste)

# D-He3: The Zero-Waste option

- ✎ In other words, Candor does reach the zero-waste option, without the need of any materials selection, low-activation materials, or further shielding.
- ✎ The final design of a fusion power reactor with DHe3 plasmas has yet to be conceived. However, the zero-waste option is a reachable goal for such reactors, as the results for Candor have indicated.

# Advantages of D-He3 - Conclusion

- ✓ The inherent cost of a fusion power reactor will hardly make it competitive with fission reactors from the economic viewpoint: a clear environmental excellence must be one of the strong points to make fusion competitive.
- ✓ At the long term, this excellence can be obtained by means of DHe3 reactors.
- ✓ In conclusion, we do not find in a fusion power reactor with DHe3 plasmas any similarity left with nuclear fission reactors.

## **Advantages of D-He3 - Conclusion**

**A fusion power reactor  
based on the D-He3 cycle  
could be the ultimate response  
to the environmental requirements  
for future nuclear power plants.**

# They Said It Couldn't Be Done

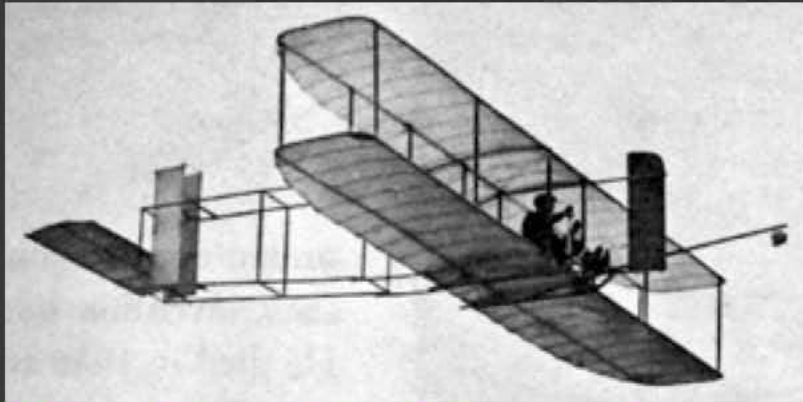

**"Man will not fly for fifty years."**

**–Wilbur Wright, 1901**

**"Heavier-than-air flying machines are impossible." –Lord Kelvin, president, Royal Society, 1895**

**"There is not the slightest indication that [nuclear energy] will ever be obtainable. It would mean that the atom would have to be shattered at will." –Albert Einstein, 1932**



**"Anyone who looks for a source of power in the transformation of the [nucleus of the] atom is talking moonshine." –Ernest Rutherford, 1933**



**"Airplanes are interesting toys but of no military value." –Marshall Foch, future WWI French commander-in-chief, 1911**

**"Space travel is utter bilge." –Dr. Richard Wooley, Astronomer Royal, space advisor to the British government, 1956**

